

LUBRICATE ALL SEALS WITH CLEAN HYDRAULIC OIL PRIOR TO ASSEMBLY.
DO NOT USE SILICONE BASED LUBRICANTS.

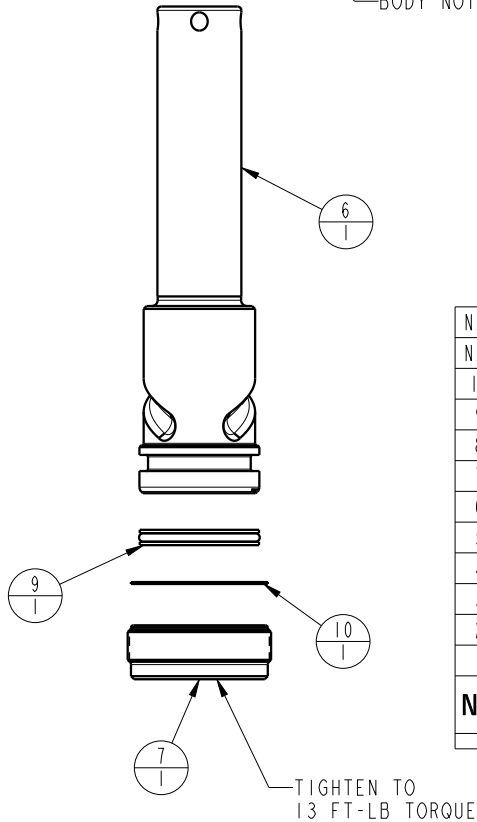

N/A	N/A	6V251204	SEAL KIT, FKM	N/A	NOTED
N/A	N/A	60251204	SEAL KIT, STANDARD	NOTED	
10	1	39T55003	GASKET, (-124)	X	X
9	1	39H11030	SEAL, T, (1 1/16X5/32X1 1/4)	X	39V11030
8	1	39F54002	BU RING, (-212 CUSTOM)	X	X
7	1	81531302	RETAINER, SC, DA, 2600, PORTED		
6	1	81511301	PLUNGER, SC, 2600#		
5	1	39053000	WIPER, SNAP-IN, (7/8)	X	X
4	2	39021006	BU RING, (-129)	X	39011068
3	1	39011046	SEAL, BEVEL W/HHEEL INSERT, 7/8 x 1/8 x 1 1/8	X	39V11046
2	1	39001040	O-RING, (-924)	X	39051029
1	1	39001039	O-RING, (-129)	X	39051028
No.	QTY	PART No.	DESCRIPTION	Std. Seal kit	FKM Seal Kit

PARTS LIST

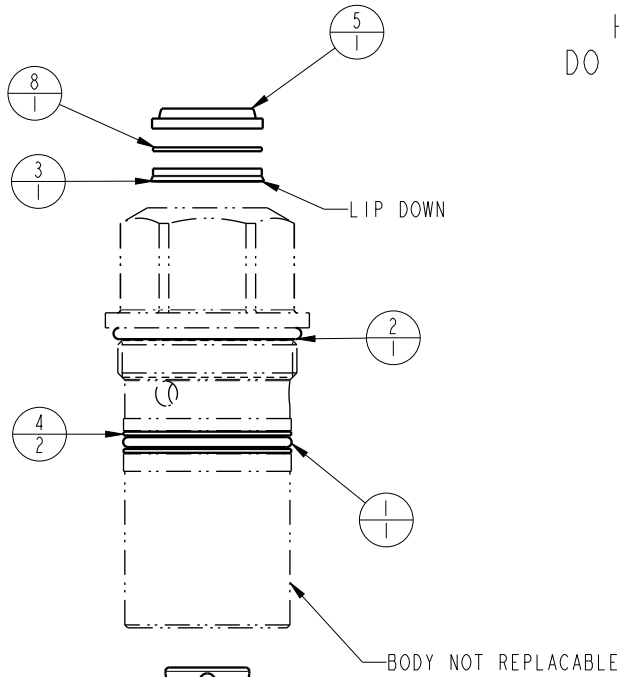

VEKTEK, INC.
1334 E. SIXTH AVE. P.O. BOX 625
EMPORIA, KS. 66801 U.S.A.

ASSEMBLIES AFFECTED

25121313

25121313F

PARTS LIST ASSY,CYL,PP,CM,6100/3100

SIZE
A

PL2522

REV
B

SHEET 1 OF 1

B	4651	RELEASE	RLK	3/30/22
REV	IN ACCORDANCE WITH ECN	EFFECTIVE DATE	REVISED BY	DATE
DRW BY:	RLK	DRAWING STATUS: Released		
DATE:	5/12/21	PRODUCTION APPROVED FOR RELEASED STATUS ONLY		

FORM FEG035_PL_ASIZE, REV. B